

**VI TELEFILTER**

**Filter specification**

**TFS 153E**

**1/5**

**Measurement condition**

Ambient temperature:	25	°C
Input power level:	0	dBm
Terminating impedance: *		
Input:	330 Ω	-13,5 pF
Output:	380 Ω	-15,2 pF

**Characteristics**

Remark:

The reference level for the relative attenuation  $a_{rel}$  of the TFS 153E is the minimum of the pass band attenuation  $a_{min}$ . The minimum of the pass band attenuation  $a_{min}$  is defined as the insertion loss  $a_e$ . The centre frequency  $f_c$  is the arithmetic mean value of the upper and lower frequencies at the 3 dB filter attenuation level relative to the insertion loss  $a_e$ . The temperature coefficient of frequency  $T_{cf}$  is valid for both the reference frequency  $f_c$  and the frequency response of the filter in the operating temperature range. The frequency shift of the filter in the operating temperature range is not included in the production tolerance scheme.

D a t a		typ. value	tolerance / limit
<b>Insertion loss</b> (reference level)	$a_e$	21,1 dB	max. 25 dB
<b>Nominal frequency</b>	$f_N$	-	153,5 MHz
<b>Centre frequency</b>	$f_c$	153,5 MHz	± 0,1 MHz
<b>Passband</b>	PB	-	$f_c$ ±2,5015 MHz
<b>Pass band ripple (p-p)</b>		0,3 dB	max. 0,7 dB
<b>Bandwidth</b>	BW		
0,7 dB		5,30 dB	min. 5,03 MHz
3 dB		5,65 dB	min. 5,60 MHz
15 dB		6,21 dB	max. 6,30 MHz
45 dB		6,68 dB	max. 9,70 MHz
<b>Relative attenuation</b>	$a_{rel}$		
$f_c$	$f_c \pm 2,5015$ MHz	0,3 dB	max. 0,7 dB
$f_c \pm 2,5015$ MHz	$f_c \pm 2,800$ MHz	2,5 dB	max. 3,0 dB
$f_c - 144,500$ MHz	$f_c - 4,825$ MHz	60 dB	min. 45 dB
$f_c \pm 3,150$ MHz	$f_c \pm 3,350$ MHz	17 dB	min. 15 dB
$f_c \pm 3,350$ MHz	$f_c \pm 3,750$ MHz	30 dB	min. 25 dB
$f_c \pm 3,750$ MHz	$f_c \pm 4,825$ MHz	55 dB	min. 40 dB
$f_c + 4,825$ MHz	$f_c + 428,500$ MHz	55 dB	min. 45 dB
<b>Absolute group delay within PB</b>		2,5 µs	max. 2,7 µs
<b>Group delay ripple within PB (p-p)</b>		60	max. 120 ns
<b>Operating temperature range</b>	OTR	-	- 25 °C ... + 80 °C
<b>Storage temperature range</b>		-	- 40 °C ... + 85 °C
<b>Frequency inversion temperature</b>		20 °C	-
<b>Temperature coefficient of frequency</b>	$T_{cf}^{**}$	-0,036 ppm/K <sup>2</sup>	-

\*) The terminating impedances depend on parasitics and q-values of matching elements and the board used, and are to be understood as reference values only. Should there be additional questions do not hesitate to ask for an application note or contact our design team.

\*\*\*)  $\Delta f_c(\text{Hz}) = T_{cf}(\text{ppm/K}^2) \times (T - T_A)^2 \times f_{CAT}(\text{MHz})$

**Generated:**

**Checked / Approved:**

Tele Filter GmbH  
 Potsdamer Straße 18  
 D 14 513 TELTOW / Germany  
 Tel: (+49) 3328 4784-0 / Fax: (+49) 3328 4784-30  
 E-Mail: [tft@telefilter.com](mailto:tft@telefilter.com)

VI TELEFILTER reserves the right to make changes to the product(s) and/or information contained herein without notice. No liability is assumed as a result of their use or application. No rights under any patent accompany the sale of any such product(s) or information.

**Filter characteristic**

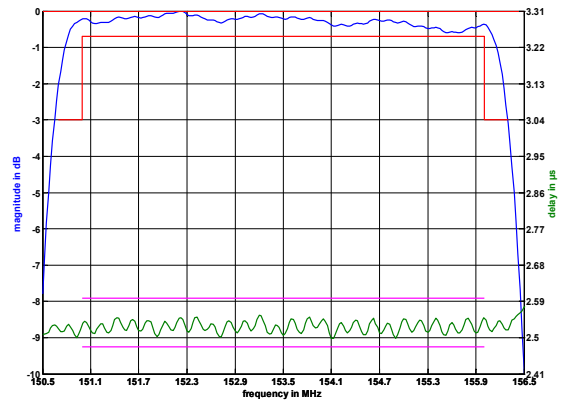
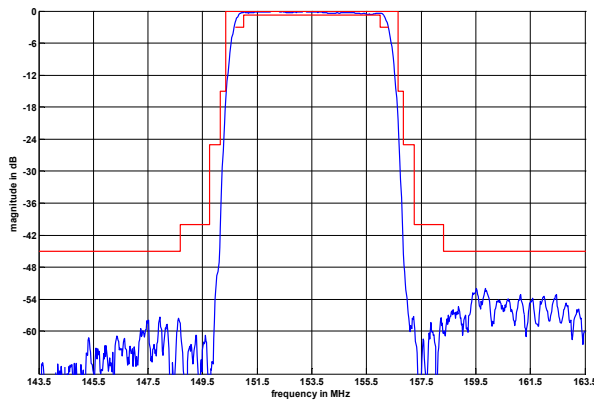

**Construction and pin connection**

(All dimensions in mm)

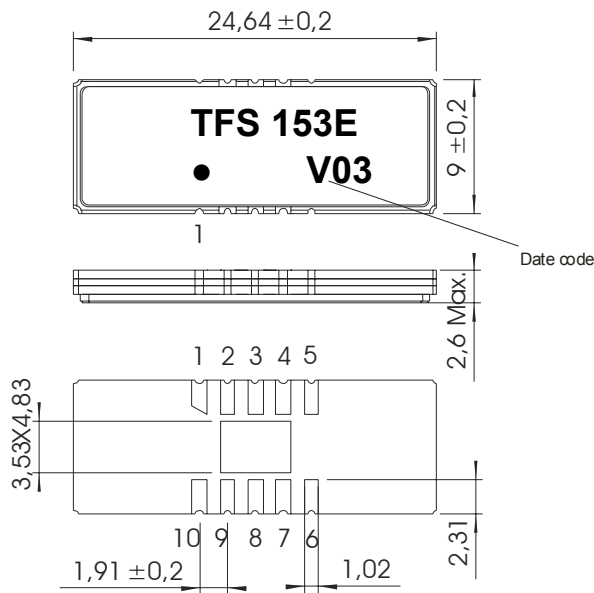

- 1 Input RF Return
- 2 Ground
- 3 Ground
- 4 Ground
- 5 Output
- 6 Output RF Return
- 7 Ground
- 8 Ground
- 9 Ground
- 10 Input

Date code: Year + week  
 V 2007  
 W 2008  
 X 2009  
 ...

**50 Ω Test circuit**

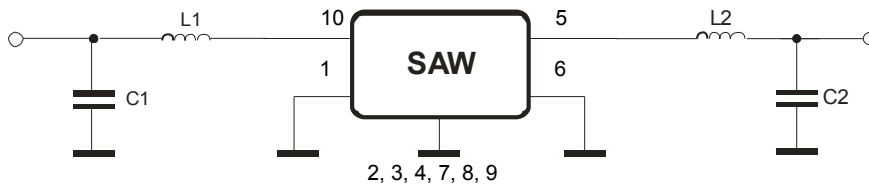

**Tele Filter GmbH**  
 Potsdamer Straße 18  
 D 14 513 TELTOW / Germany  
 Tel: (+49) 3328 4784-0 / Fax: (+49) 3328 4784-30  
 E-Mail: [tft@telefilter.com](mailto:tft@telefilter.com)

VI TELEFILTER reserves the right to make changes to the product(s) and/or information contained herein without notice. No liability is assumed as a result of their use or application. No rights under any patent accompany the sale of any such product(s) or information.

**Stability characteristics, reliability**

After the following tests the filter shall meet the whole specification:

1. Shock: 500g, 1 ms, half sine wave, 3 shocks each plane;  
DIN IEC 68 T2 - 27
2. Vibration: 10 Hz to 500 Hz, 0,35 mm or 5 g respectively, 1 octave per min, 10 cycles per plan, 3 plans;  
DIN IEC 68 T2 - 6
3. Change of temperature: -55 °C to 125°C / 30 min. each / 10 cycles  
DIN IEC 68 part 2 – 14 Test N
4. Resistance to solder heat (reflow): reflow possible: three times max.;  
for temperature conditions refer to the attached "Air reflow temperature conditions" on page 4;
5. ESD ANSI/ESD S20.20-1999, class 1A for HBM

This filter is RoHS compliant (2002/95/EG, 2005/618/EG)

**Packing**

- Tape & Reel: IEC 286 – 3, with exception of value for N and minimum bending radius;  
tape type II, embossed carrier tape with top cover tape on the upper side;
- |   |                    |
|---|--------------------|
| max. pieces of filters per reel:                    | <MAXPIECESPERREEL> |
| reel of empty components at start:                  | min. 300 mm        |
| reel of empty components at start including leader: | min. 500 mm        |
| trailer:  | min. 300 mm        |

**Tape (all dimensions in mm)**

- W : 44,00 ± 0,3
- Po : 4,00 ± 0,1
- Do : 1,50 +0,1/-0
- E : 1,75 ± 0,1
- F : 20,20 ± 0,15
- P2 : 2,00 ± 0,15
- P1 : 16,00 ± 0,1
- D1(min) : 2,00
- Ao : 9,30 ± 0,1
- Bo : 24,90 ± 0,1
- So : 40,40 ± 0,1
- Ct : 38,0 ± 0,1

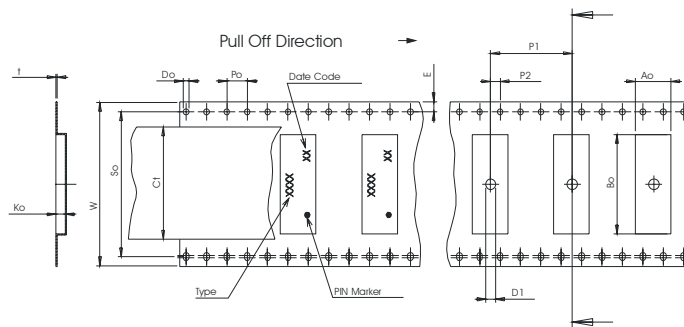

**Reel (all dimensions in mm)**

- A : 330
- W1 : 44,4 +2/-0
- W2(max) : 50,4
- N(min) : 100
- C : 13,0 +0,5/-0,2

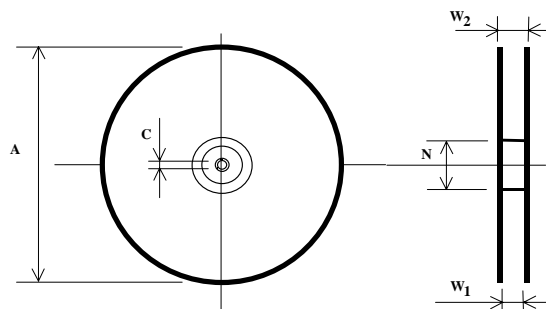

The minimum bending radius is 45 mm.

**Tele Filter GmbH**  
**Potsdamer Straße 18**  
**D 14 513 TELTOW / Germany**  
**Tel: (+49) 3328 4784-0 / Fax: (+49) 3328 4784-30**  
**E-Mail: [tft@telefilter.com](mailto:tft@telefilter.com)**

VI TELEFILTER reserves the right to make changes to the product(s) and/or information contained herein without notice. No liability is assumed as a result of their use or application. No rights under any patent accompany the sale of any such product(s) or information.

**Air reflow temperature conditions**

Conditions	Exposure
Average ramp-up rate (30°C to 217°C)	less than 3°C/second
> 100°C	between 300 and 600 seconds
> 150°C	between 240 and 500 seconds
> 217°C	between 30 and 150 seconds
Peak temperature	max. 260°C
Time within 5°C of actual peak temperature	between 10 and 30 seconds
Cool-down rate (Peak to 50°C)	less than 6°C/second
Time from 30°C to Peak temperature	no greater than 300 seconds

**Chip-mount air reflow profile**

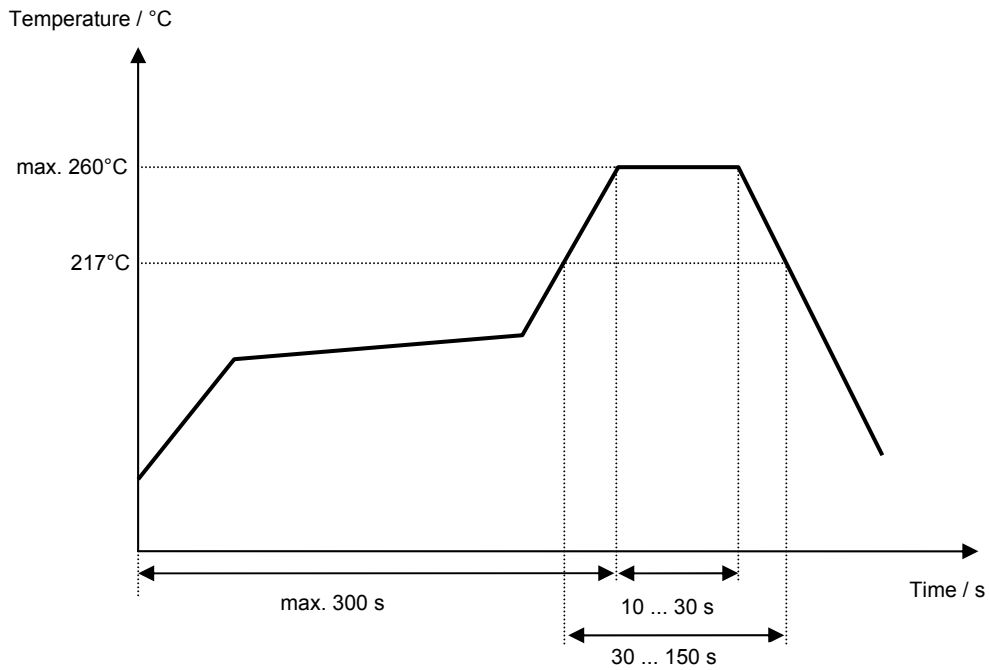

Tele Filter GmbH  
 Potsdamer Straße 18  
 D 14 513 TELTOW / Germany  
 Tel: (+49) 3328 4784-0 / Fax: (+49) 3328 4784-30  
 E-Mail: [tft@telefilter.com](mailto:tft@telefilter.com)

VI TELEFILTER reserves the right to make changes to the product(s) and/or information contained herein without notice. No liability is assumed as a result of their use or application. No rights under any patent accompany the sale of any such product(s) or information.

**VI TELEFILTER****Filter specification****TFS 153E****5/5****History**

<b>Version</b>	<b>Reason of changes</b>	<b>Name</b>	<b>Date</b>
1.0	- development specification	Pfeiffer	03.01.2007
1.1	- add of terminating impedances and typical values - filter characteristics corrected	Pfeiffer	18.01.2007

---

**Tele Filter GmbH**  
**Potsdamer Straße 18**  
**D 14 513 TELTOW / Germany**  
**Tel: (+49) 3328 4784-0 / Fax: (+49) 3328 4784-30**  
**E-Mail: [tft@telefilter.com](mailto:tft@telefilter.com)**

---

VI TELEFILTER reserves the right to make changes to the product(s) and/or information contained herein without notice. No liability is assumed as a result of their use or application. No rights under any patent accompany the sale of any such product(s) or information.